



**Township of Lanark Highlands
Request for Quotation
Fabricate & Install Mechanical
Dehumidifier Stand**

1.0 PROJECT DESCRIPTION

The Corporation of the Township of Lanark Highlands (hereinafter referred to as the Township) is seeking proposals from qualified firms/individuals to provide services concerning the fabrication and installation of one (1) dehumidifier stand for the Lanark & District Community Centre.

The purpose of this Request for Quotation (RFQ) is to supply and build a mechanical dehumidifier stand for the Lanark & District Community Centre . This RFQ also addresses the exact needs for the project outlined in the Project Scope. Each component should be submitted separately as the Township **may accept the lowest bid for each component** regardless of bidders total bid.

Design fabrication and installation shall be in accordance with the National/Ontario Building code and CSA S16 (latest edition) "Design of Steel Structures".

Welding shall only be undertaken by a company Certified by the Canadian Welding Bureau to the requirements of CSA Standard W47.1 (latest edition) "Certification of Companies for the Fusion Welding of Steel" in Division 1 or 2. All welding shall be done in accordance with and meet the quality requirements of CSA Standard W59 (latest edition) "Welded Steel Construction". All welders employed by the company shall hold valid qualifications issued by the Canadian Welding Bureau. All welding shall be done in accordance with welding procedures approved by the Canadian Welding Bureau.

Only tenders supplied with current copies of the CWB Letter of Validation will be accepted.

2.0 PROJECT SCOPE

Component Number 1:

To fabricate and install:

- One large size platform to support the arena dehumidifier.
- The platform must be suspended at a minimum of 14-22 feet above ice level.

Component Number 2:

- Engineering Firm McIntosh Perry has provided detailed specifications for the platform.
- The plans (SCHEDULE "A") must be carefully examined by bidders before submitting an RFQ.

3.0 PROJECT AUTHORITY

For further information regarding all aspects of this Request for Quotation, please contact:

Chelsea Dawes, Manager of Facilities / Community Affairs
Township of Lanark Highlands
75 George Street, P.O. Box 340
Lanark, ON K0G 1K0



**Township of Lanark Highlands
Request for Quotation
Fabricate & Install Mechanical
Dehumidifier Stand**

Email: commaffairs@lanarkhighlands.ca
Telephone: 613-259-2398 ext. 252
Fax: 613-259-2291

4.0 PROPOSAL VALIDITY

Proposals shall remain valid and open for acceptance by the Township for a period of thirty (30) calendar days, following the due date for receipt of submissions.

5.0 SUBMISSION OF PROPOSAL

Please provide your proposal, signed by an authorized official, in a sealed envelope clearly identified as **REQUEST FOR QUOTATION – FABRICATE & INSTALL MECHANICAL DEHUMIDIFIER STAND** addressed to the Project Authority. Proposals **MUST** be received at this location **NOT LATER THAN 4:00 pm on June 19th, 2020**. Proposals received after the above due date and time will not be considered, and will be returned unopened, to the originator.

6.0 INQUIRIES

All inquiries regarding this Request for Quotation are to be directed to the Project Authority. Inquiries must be received in writing (facsimile is allowable) no later than June 15th, 2020. Both the questions and the answers will be distributed to all known potential proponents by way of a written addendum, without stating the source(s) of the inquiry. Information obtained from any other source is not official and should not be relied upon.

7.0 RIGHTS RESERVED BY THE TOWNSHIP

The Township will not be responsible for any costs incurred in the preparation and submission of this Request for Quotation.

The lowest cost proposal will not necessarily be accepted, and the Township reserves the right, in its sole discretion, to accept or reject any or all proposals and/or to reissue the Request for Quotation in its original or revised form. The Township also reserves the right to cancel this Request for Quotation at any time, without penalty or cost to the Township.

This Request for Quotation and the resulting proposals should not be considered a commitment by the Township to enter into any contract with any service provider. The Township of Lanark Highlands reserves the right to cancel this tender within 30 days of written notice. This tender is subject to council approval.

8.0 BASIS OF SELECTION

The onus is on the applicant to demonstrate their expertise, understanding and capacity to provide the materials outlined in Section 2 herein. The proposals will be assessed based on cost and according to how well they assure the Township of success in relation to the RFQ requirements. Please address each component in your submission. The detail and clarity of the written submission will be considered indicative of the applicant's expertise and competence. All proposals **must** contain the following information:

- Name, address, e-mail, telephone and fax number of the principal contact person;
- A list of related projects in the past three (3) years;



**Township of Lanark Highlands
Request for Quotation
Fabricate & Install Mechanical
Dehumidifier Stand**

- At least three (3) client references for whom comparable work has been completed
- Contract rate with each component prices separately

9.0 INDEMNIFICATION AND LIABILITY INSURANCE

The successful bidder shall at their own expense within 10 days of notification of acceptance and prior to the commencement of any work, obtain and maintain until the termination of the contract or otherwise stated, provide the Township with evidence of Commercial General Liability Insurance issued on an occurrence basis for an amount of not less than \$2,000,000 per occurrence for any negligent acts or omissions by the contractor relating to its obligations under this Agreement. Such insurance shall include, but is not limited to bodily injury and property damage including the loss of use; personal injury; contractual liability; premises, property and operations; non-owned automobile; broad form property damage; owners and contractors protective; occurrence property damage; products and completed operations; employees as Additional Insured(s); contingent employers liability; tenants legal liability; cross liability and severability of interest clause.

Such insurance shall add the Township as an Additional Insured with respect to the operations of the bidder. This insurance shall be non-contributing with and apply as primary and not as excess of any insurance available to the Township. The successful bidder shall indemnify and hold the Township, its officers and employees harmless from and against any liability, loss, claims, demands, costs and expenses, including reasonable legal fees, occasioned wholly or in part by any acts or omissions either in negligence or acts of omissions whether willful or otherwise by the bidder, its agents, officers, employees or other persons for whom the bidder is legally responsible.

10.0 MUNICIPAL FREEDOM OF INFORMATION AND PROTECTION OF PRIVACY ACT

Personal information collected from applications is collected under the authority of the Municipal Freedom of Information and Protection of Privacy Act, and will be used to determine qualifications. Questions about the collection of Information should be directed to the Deputy Clerk at 613-259-2398 ext. 231.

11.0 HEALTH AND SAFETY

The successful contractor shall be responsible for providing all safety training and related safety equipment, for employing safe work practices at all times while carrying out work for the Township, and for complying with all applicable health and safety legislation/regulations.

12.0 EVALUATION

Quotations will be evaluated by the Community Services Department and the Clerk/Chief Administrative Officer prior to final approval by Township Council.

Right to Accept or Reject Tenders

The owner reserves the right to reject any or all tenders or to accept any tender should it be deemed to be in their best interest to do so. Tenders which are incomplete, conditional or obscure, or which contain additions not called for, erasures, alterations, or irregularities of any kind, may be rejected as information.



**Township of Lanark Highlands
Request for Quotation
Fabricate & Install Mechanical
Dehumidifier Stand**

BID FORM FOR ITEMS AND UNIT PRICES

		BID	
ITEM	QTY	DESCRIPTION	PRICE
1	1	GENERAL NOTES 1. DESIGN CONFORMS TO OBC 2012. 2. DESIGN LOADS: DEAD LOAD = 1000 LB; LIVE LOADS = 40 PSF 3. STEEL - HSS, W SHAPES IS G40.21 50 W; PLATE, CHANNEL AND ANGLE IS 44W. 4. ALL WELDED CONSTRUCTION 1 4" FILLETS ALL AROUND OR FULL PENETRATION ALL AROUND, BY CERTIFIED WELDERS. 5. BOLTED CONNECTION CAN BE REPLACED WITH 1 4" FILLET WELD ALL AROUND. 6. ALL STEEL SHALL BE HOT DIPPED GALVANIZED. 7. ALL BOLTS SHALL BE 1 2"Ø A325, UNLESS OTHERWISE NOTED.	\$
		Subtotal, excluding HST	\$

Time is of the essence and may be a consideration of award. Therefore, the tendering company shall indicate in his/her tender, the anticipated delivery date of the equipment, based on Municipal Council's awarding this Tender to the Bidder of choice.

Anticipated delivery date: _____

By submitting this tender form, the bidder acknowledges the owner's right to accept or reject any submission at its sole discretion.

The undersigned affirms that he/she is duly authorized to execute this Bid.

BIDDERS NAME: _____

POSITION: _____

BIDDERS SIGNATURE: _____

DATED THIS _____ DAY OF _____, 2020

Schedule "A"

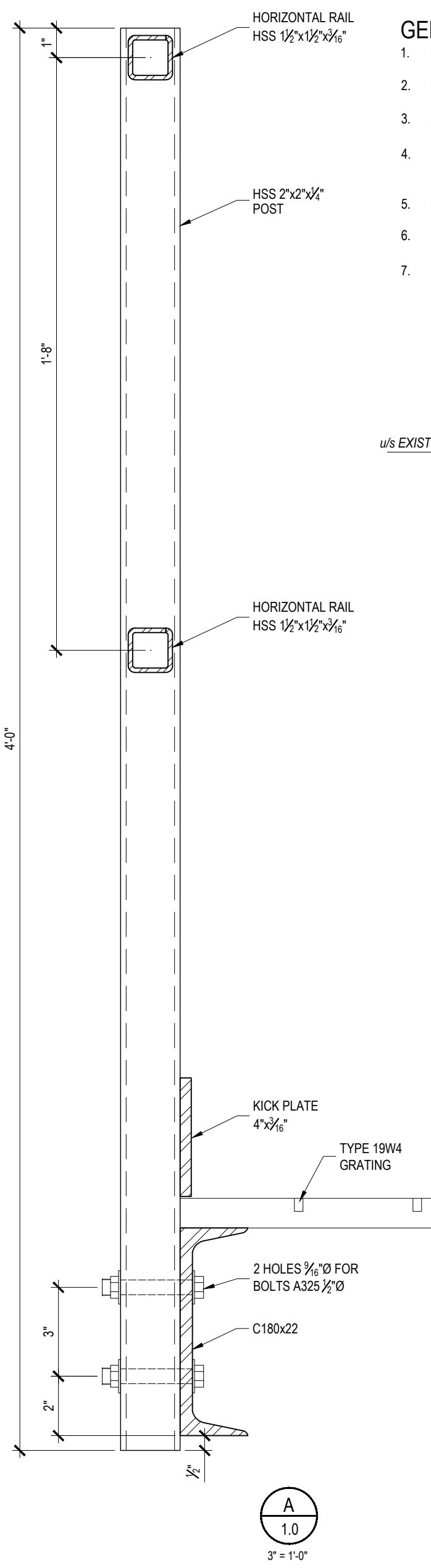
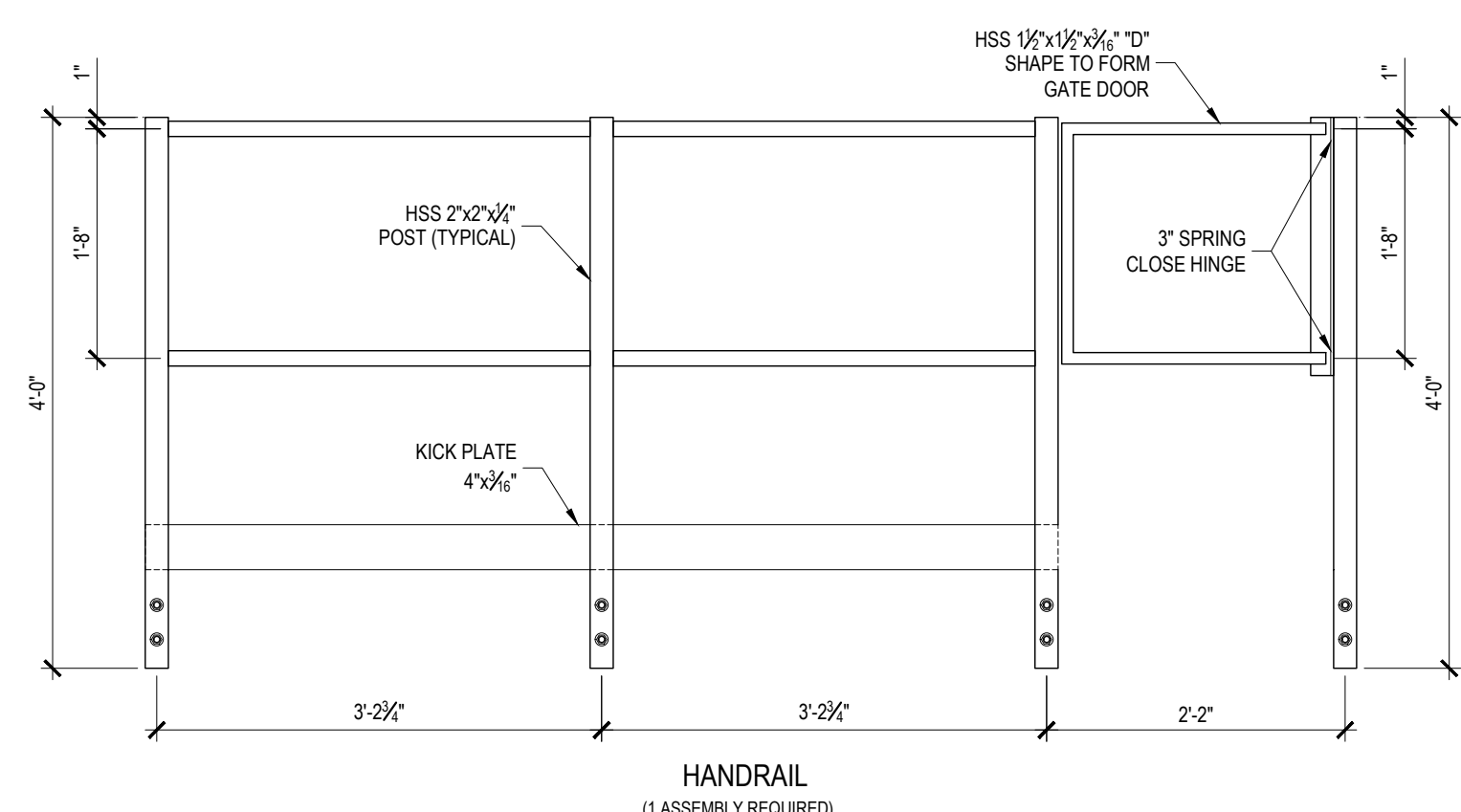
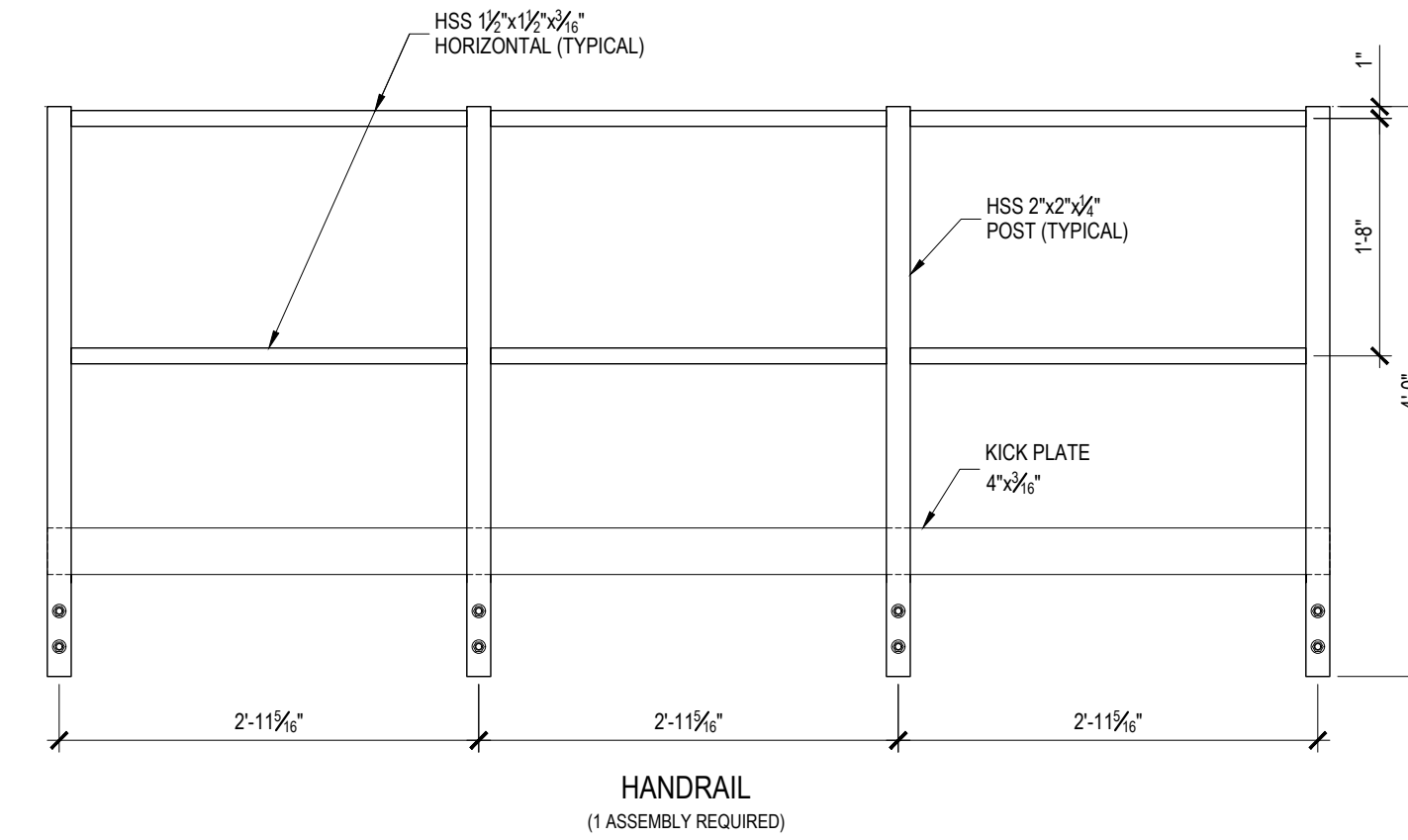
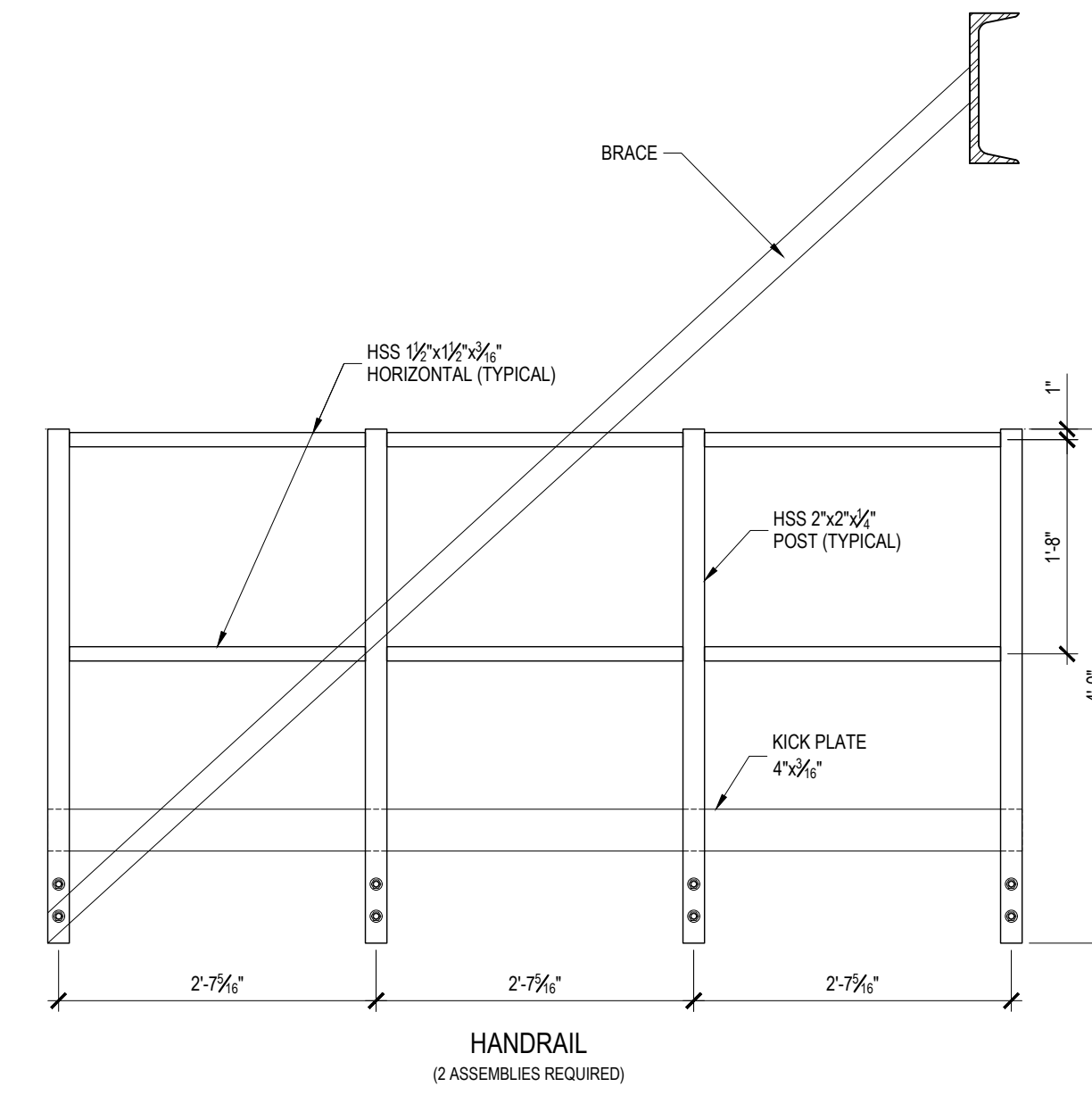
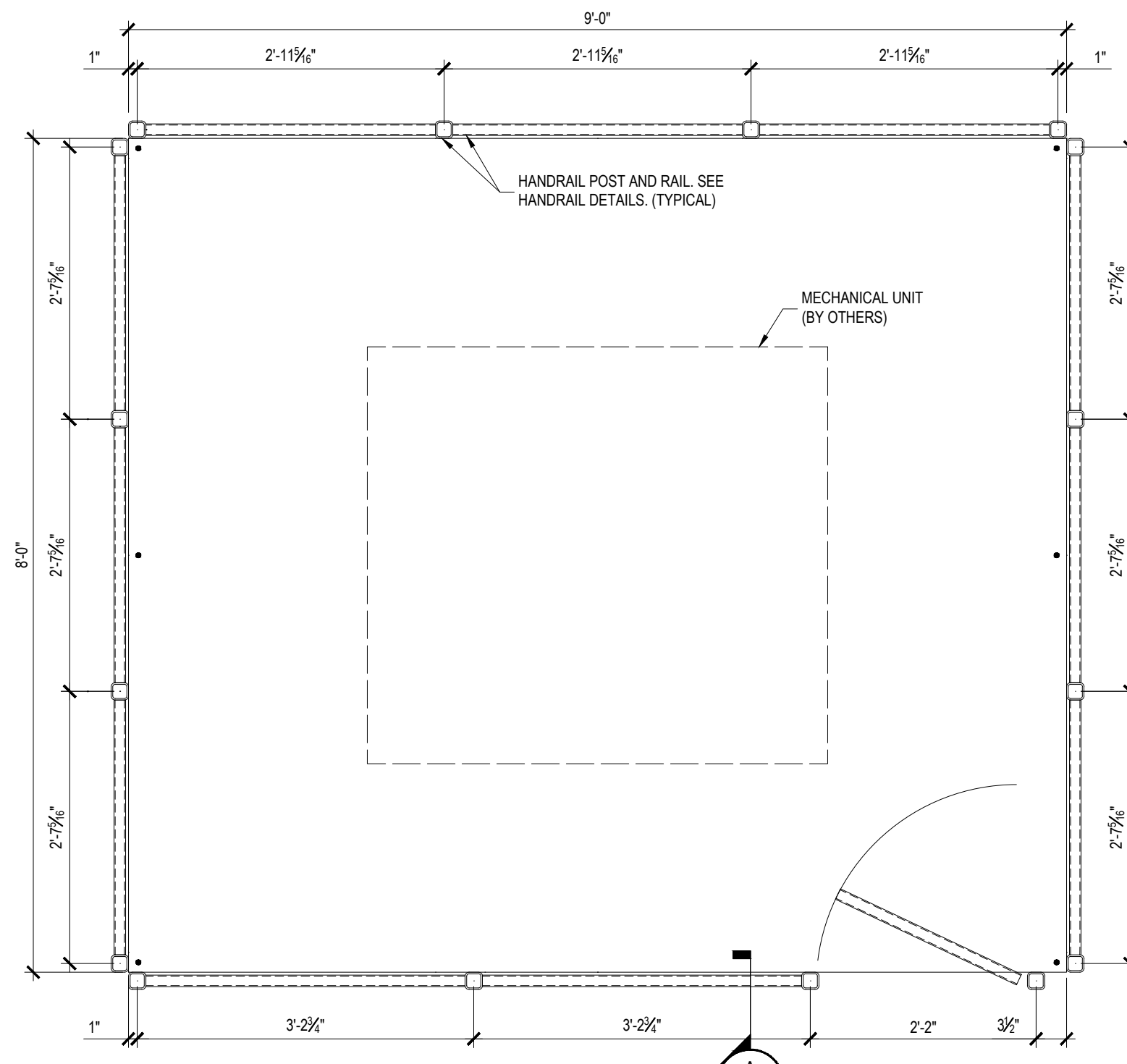
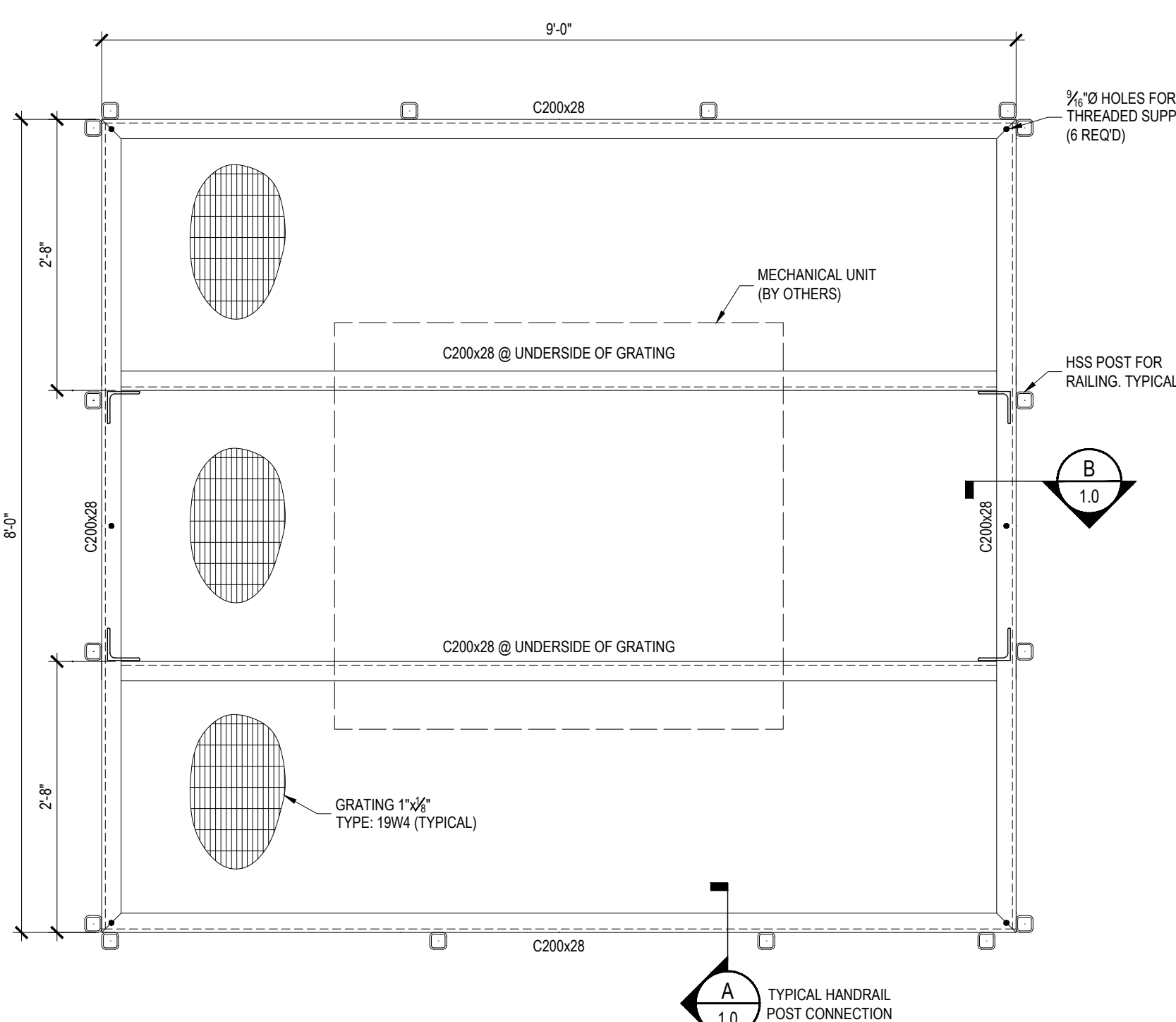

- ### GENERAL NOTES
- DESIGN CONFORMS TO OBC 2012.
 - DESIGN LOADS: DEAD LOAD = 1000 LB; LIVE LOADS = 40 PSF
 - STEEL - HSS, W SHAPES IS G40 21 50 W; PLATE, CHANNEL AND ANGLE IS 4W.
 - ALL WELDED CONSTRUCTION 1/2" FILLETS ALL AROUND OR FULL PENETRATION ALL AROUND, BY CERTIFIED WELDERS.
 - BOLTED CONNECTION CAN BE REPLACED WITH 1/2" FILLET WELD ALL AROUND.
 - ALL STEEL SHALL BE HOT DIPPED GALVANIZED.
 - ALL BOLTS SHALL BE 3/8" A325, UNLESS OTHERWISE NOTED.

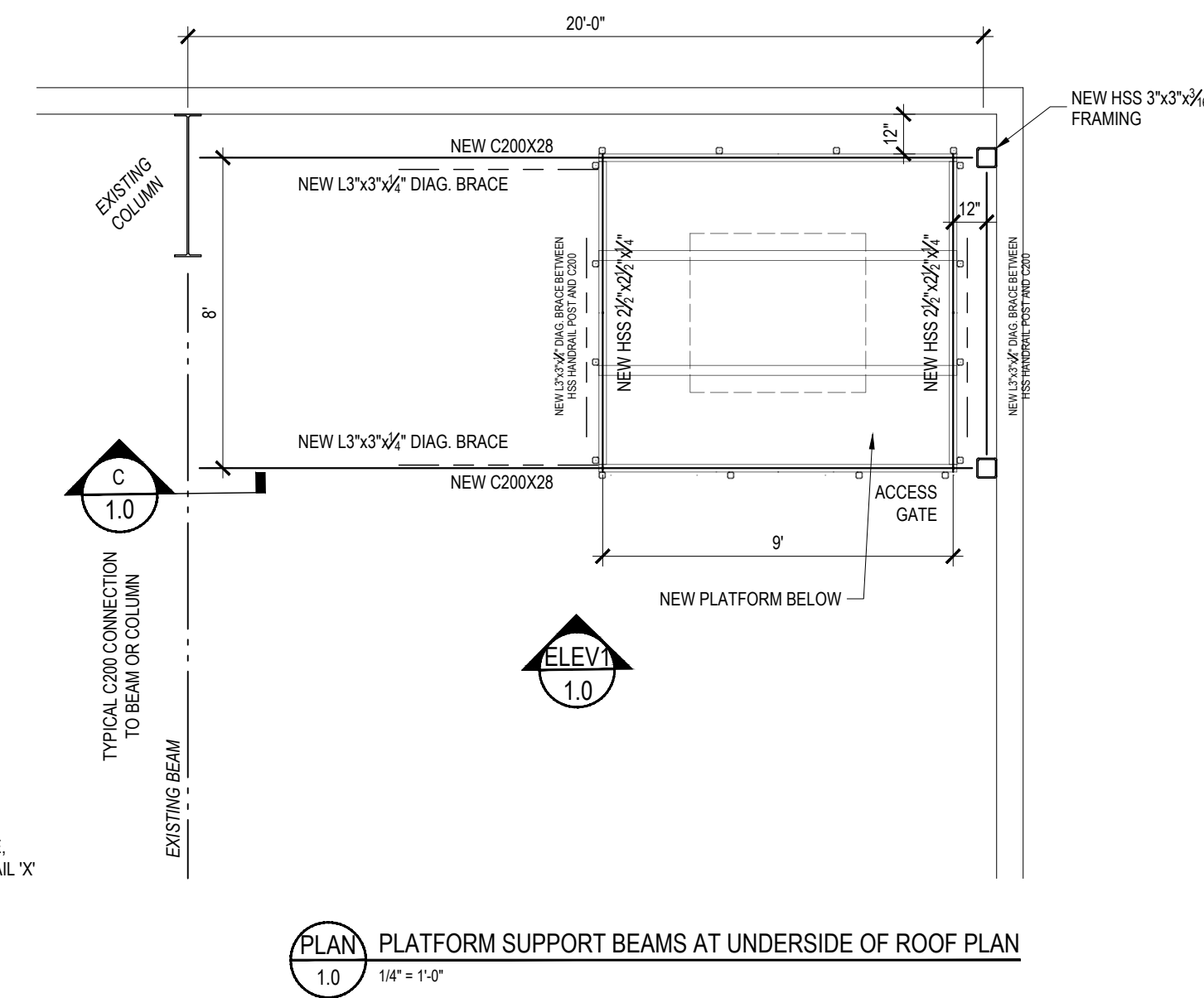
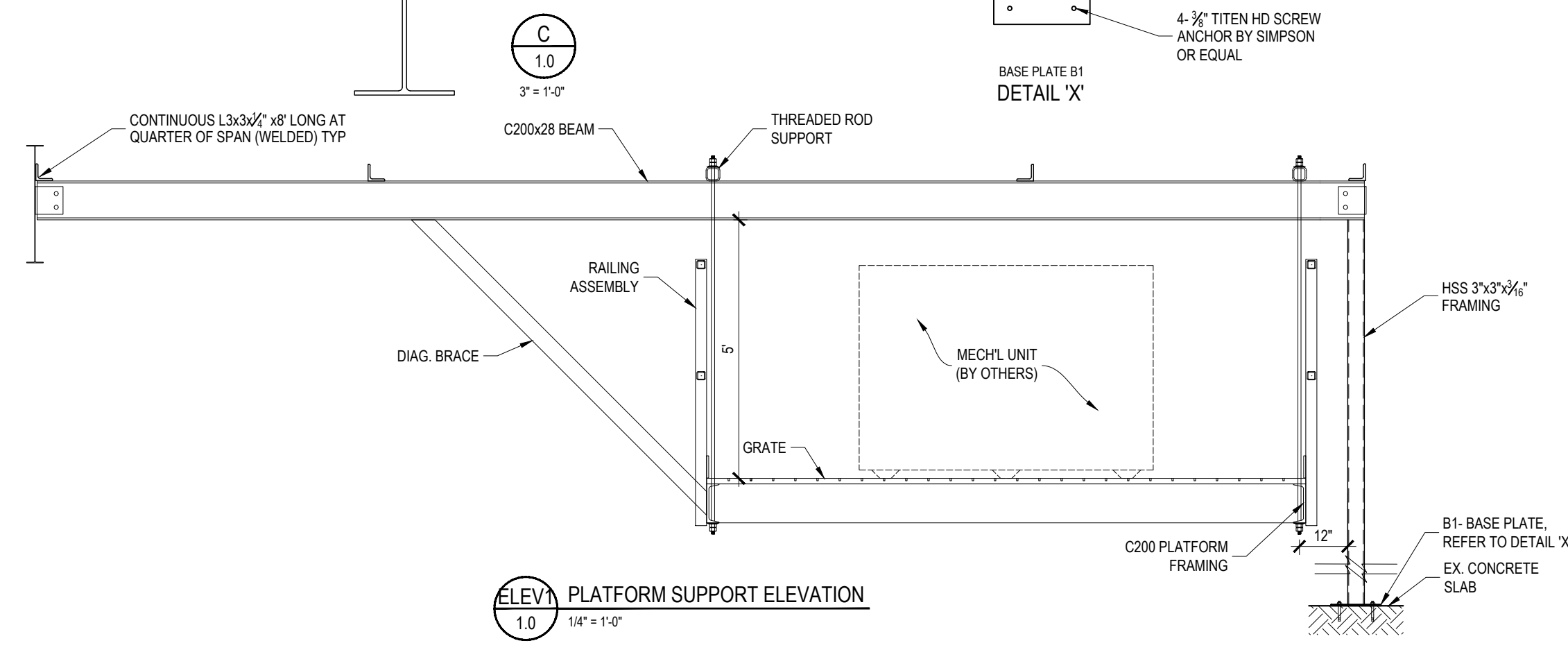
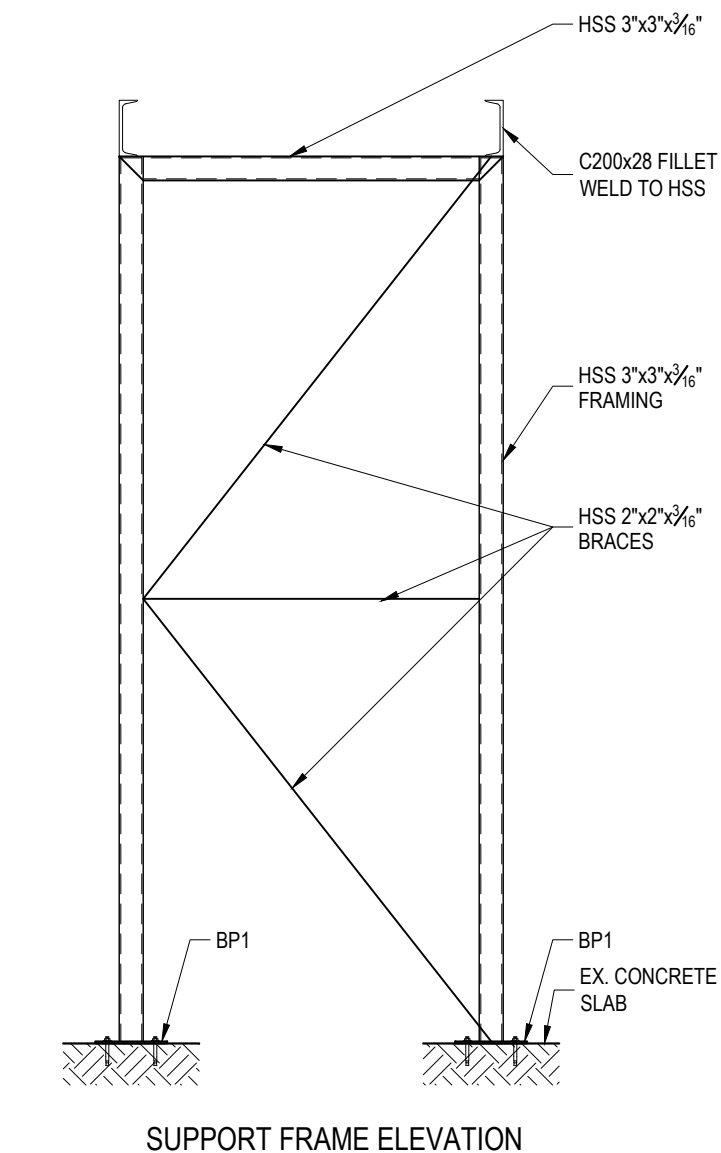
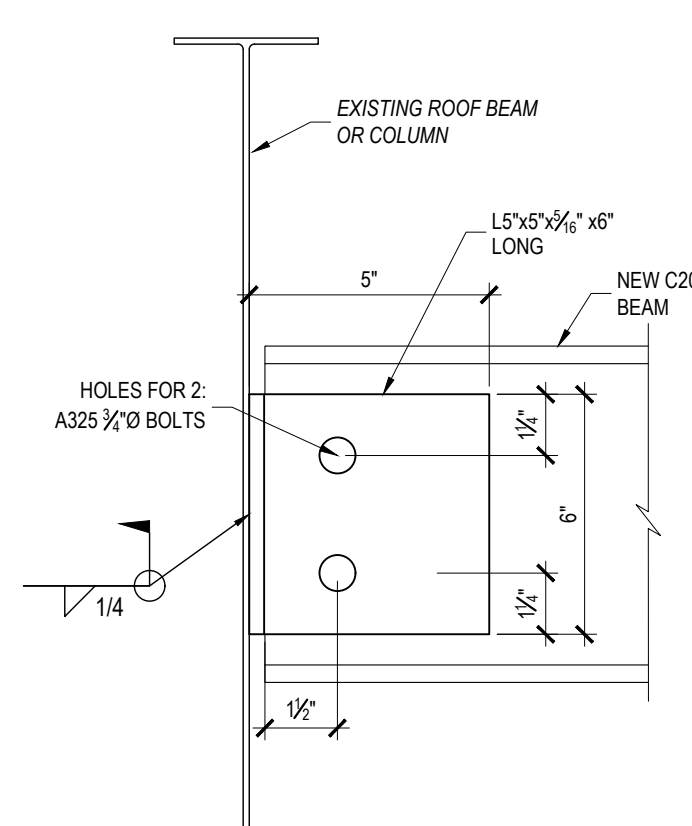
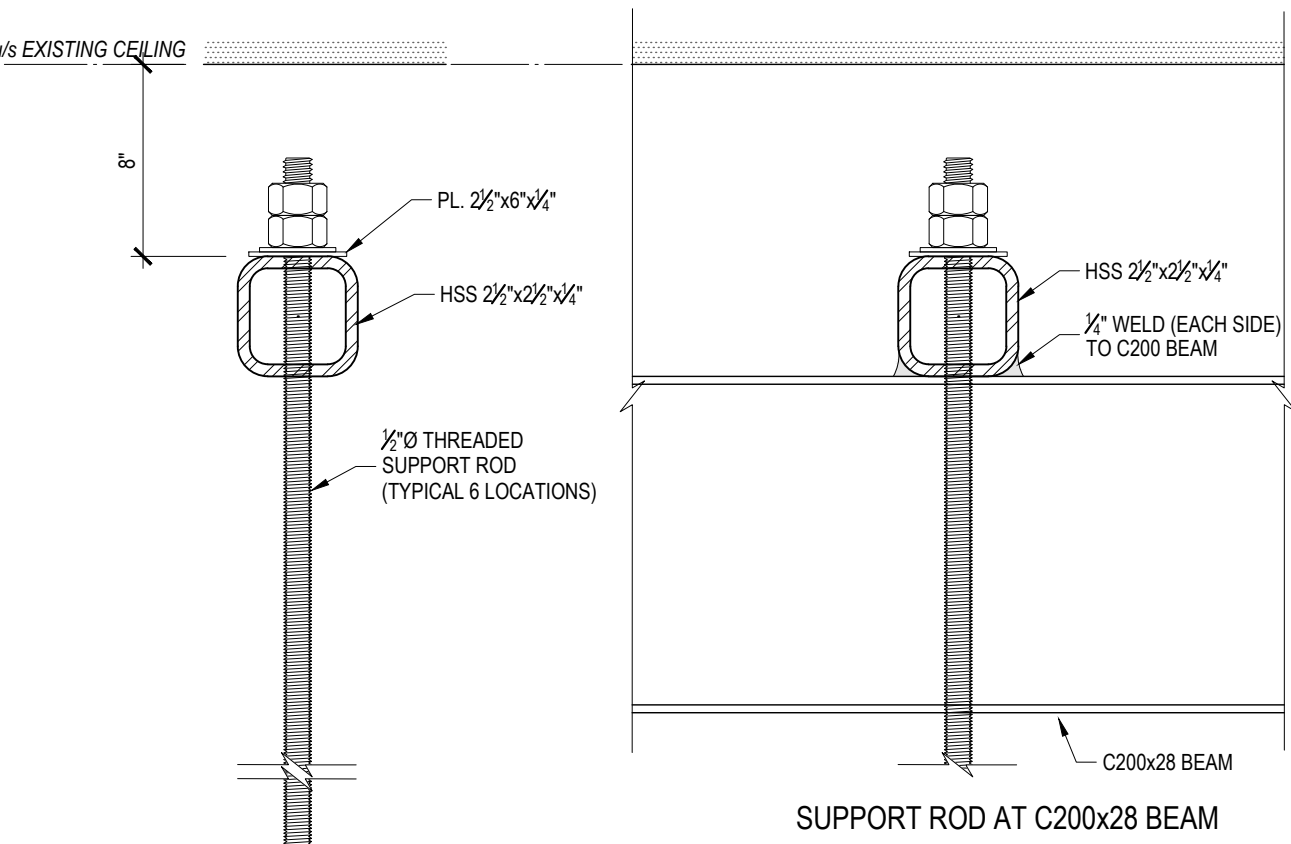

No.	Revision/Issue	Date

Check and verify all dimensions before proceeding with the work. Do not scale drawings.

McINTOSH PERRY

115 Walgreen Road, RR 3
Carp, ON K0A 1L0
Tel: 613-836-2184 Fax: 613-836-3742
www.mcintoshperry.com

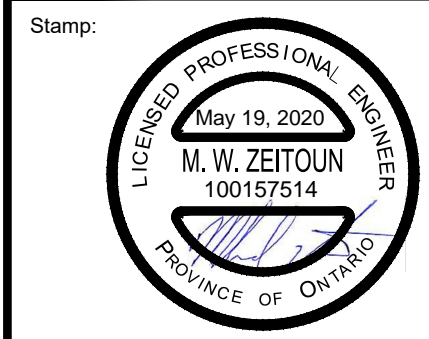

Client:
Township of Lanark Highlands
75 George Street, PO BOX 340
Lanark, Ontario K0G 1K0

Project:
Lanark Community Centre
New Mechanical Platform

67 Princess St Lanark, Ontario

Drawing Title:
Plans and Details

Scale: As Noted
Project Number: OCM-19-0531

Drawn by: dmw
Checked by: MZ
Designed by: RB
Date: 8 May 2020

Drawing Number:
SHEET 1 of 1

S1.0

FILE NAME: \\cm\share\perry\Projects\2019 - 2020\OCM-19-0531\19-0531-01 - Township of Lanark Highlands - Lanark Community Centre New Mechanical Platform - Drawings\01 - Platform S&C - Drawing\01 - Structural Framing\CMC19-0531-01.dwg
LAST SAVED: Friday, May 19, 2023 10:48:20 AM
LAST SAVED BY: M. Zeitoum
LAST PLOTTED: Tuesday, May 19, 2023 8:28:54 AM
C:\Users\dmw\AppData\Local\Temp\1\AutoCAD\2023\cm190531-01-01.dwg